

6690



MODEL 6690

FROZEN BEVERAGE FREEZER

Single flavor, Counter-top

Product Offering

Vary your menu by offering shakes & smoothies or frozen cocktails, fruit juices, coffees, cappuccino and tea slush beverages, all served at the desired thickness.

Freezing Cylinder

One, 6.9 Liter (7.3 quarts)

Mix Hopper

One, 25 Liters (26.4 quarts)

Refrigerated to maintain mix below 4°C (40°F)

Approved for dairy and non-dairy products.

Indicator Lights

Add Mix light alerts the operator to add mix.

When Mix Out light turns ON, the unit automatically shuts down to prevent damage.

Automatic Consistency Control

Specially designed viscosity control automatically maintains superior product quality.

Adjustable control allows the operator to serve a wide variety of frozen beverages at the desired thickness.

Output

60 quarts per hour

Safety Protections

- High pressure switch prevents compressor overheat.
- Thermal overload protects from motor overheat.



ISO9001
CERTIFIED

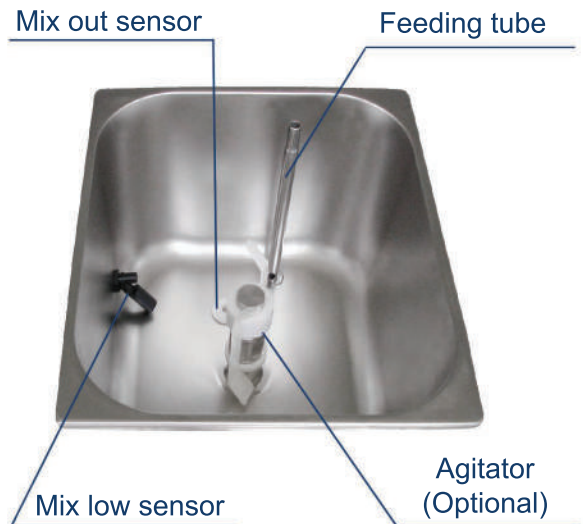

SPACEMAN USA

CORPORATE OFFICE: 4635 NAUTILUS CT S #C | BOULDER, CO 80301

PHONE: (888) 610-5520

WEB: WWW.SPACEMANUSA.COM

rev.jr.71515

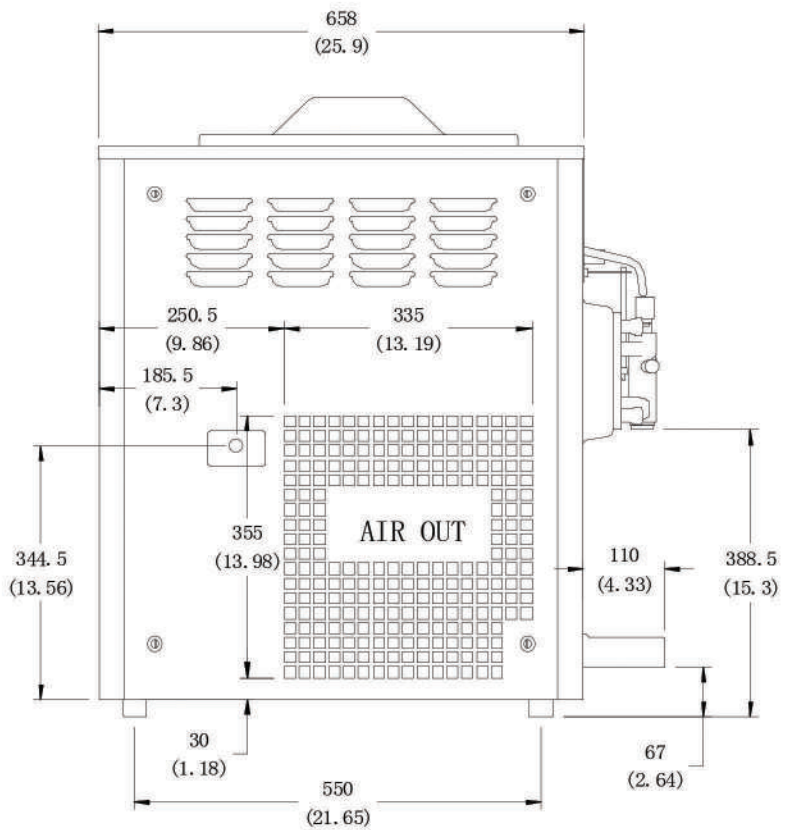
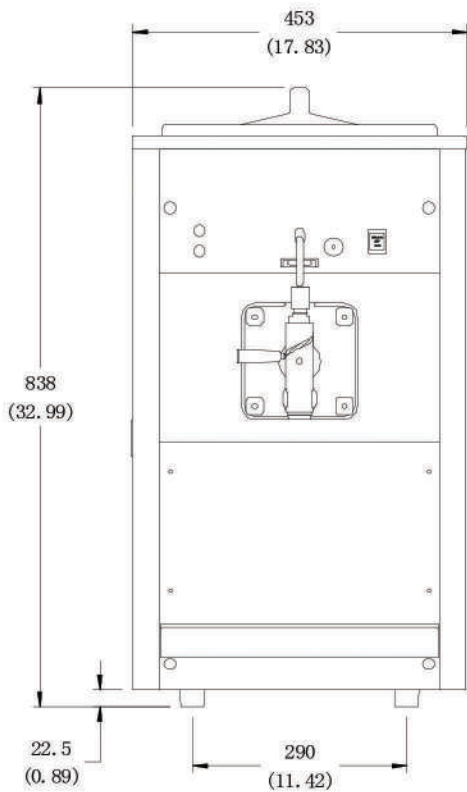

Weight	Kg / lb
Net	123 / 271
Shipping	137 / 302

Packaging Volume 0.46 CBM / 16.36 CBF

Dimensions	Net (mm/in)	Shipping (mm/in)
Width	453 / 17.8	510 / 20.1
Depth	658 / 25.9	845 / 33.3
Height	838 / 33.0	1075 / 42.3

Electrical	Maximum Fuse Size	Min. Circuit Ampacity	Poles (P) Wires(W)
208-230/60/1	20	15	2P/3W

PLUG: L6-20

This unit may be manufactured in other electrical characteristics. Refer to the local distributor for availability. (For exact electrical information, always refer to the data label of the unit.)

Note
Continuing research results in steady improvements, therefore, these specifications are subject to change without notice.

Specifications

Electrical

One dedicated electrical connection is required. Unit shall be cord connected or permanently connected. Consult your local Spaceman distributor for available cord & receptacle specifications as per local codes.

Motor

One, 4/5HP

Refrigeration System

Main Compressor: 8,000 BTU/HR, R404A
Hopper Compressor: 480 BTU/HR, R134A

(BTUs may vary depending on compressor used.)

Air Cooled

Minimum clearance of 152mm (6") on both sides is required to achieve optimum performance.

The rear of the unit may be placed against a wall

Max room temperature 95° F